

# Next Generation Fare Gates Update

# Agenda

Swinging Forward!

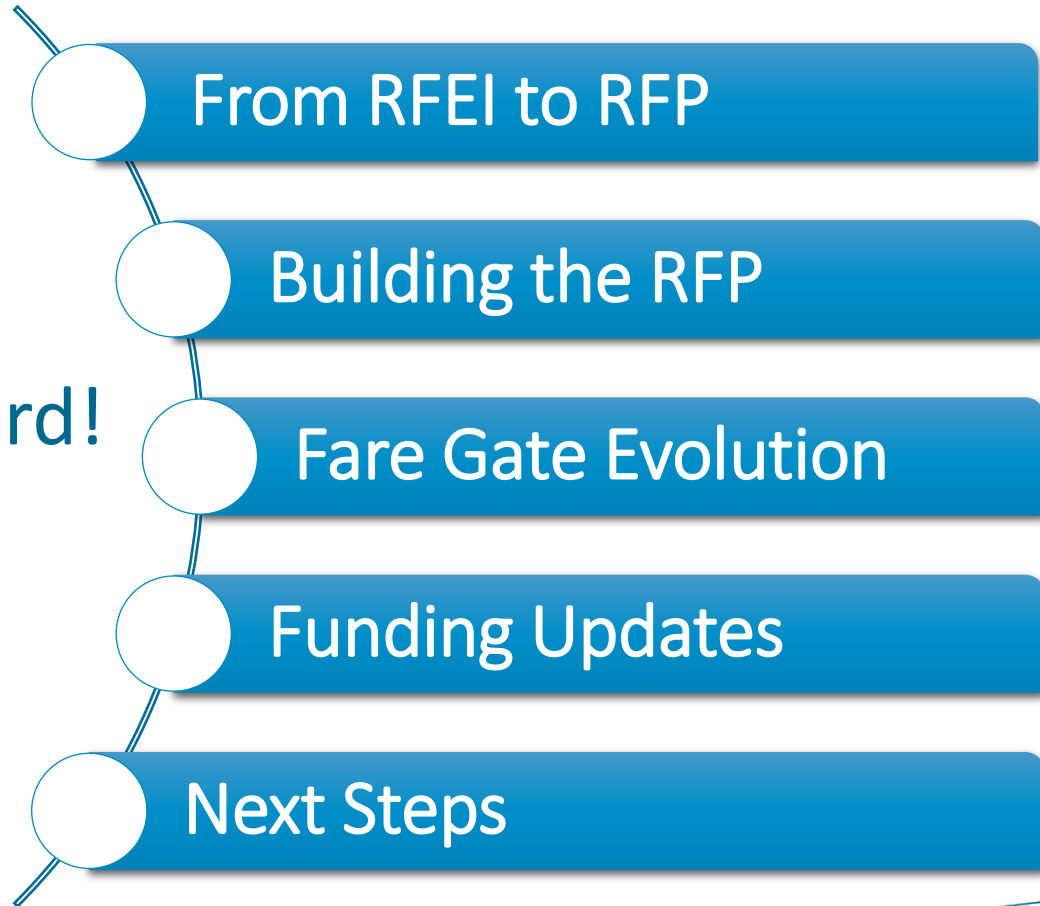

# Evolution of the RFP

FY 21

FY 22



BART Board  
Update on RFEI

Engage  
Consultant

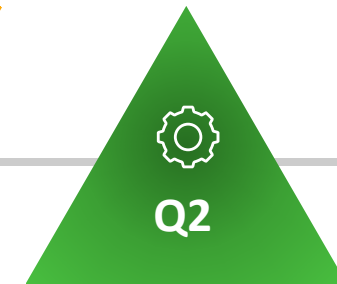

Draft RFP Documents  
3 Volumes  
500 Requirements

Board Approval for  
Competitive Negotiation P  
rocurement



Advertise  
RFP  
Evaluate  
Proposals

# RFP Workshops

## Develop Scope of Work

**Gather Standards & Requirements**

**Industry Engagement through RFEI**

**BART Stakeholder Workshops**

**Finalize Technical Requirements**

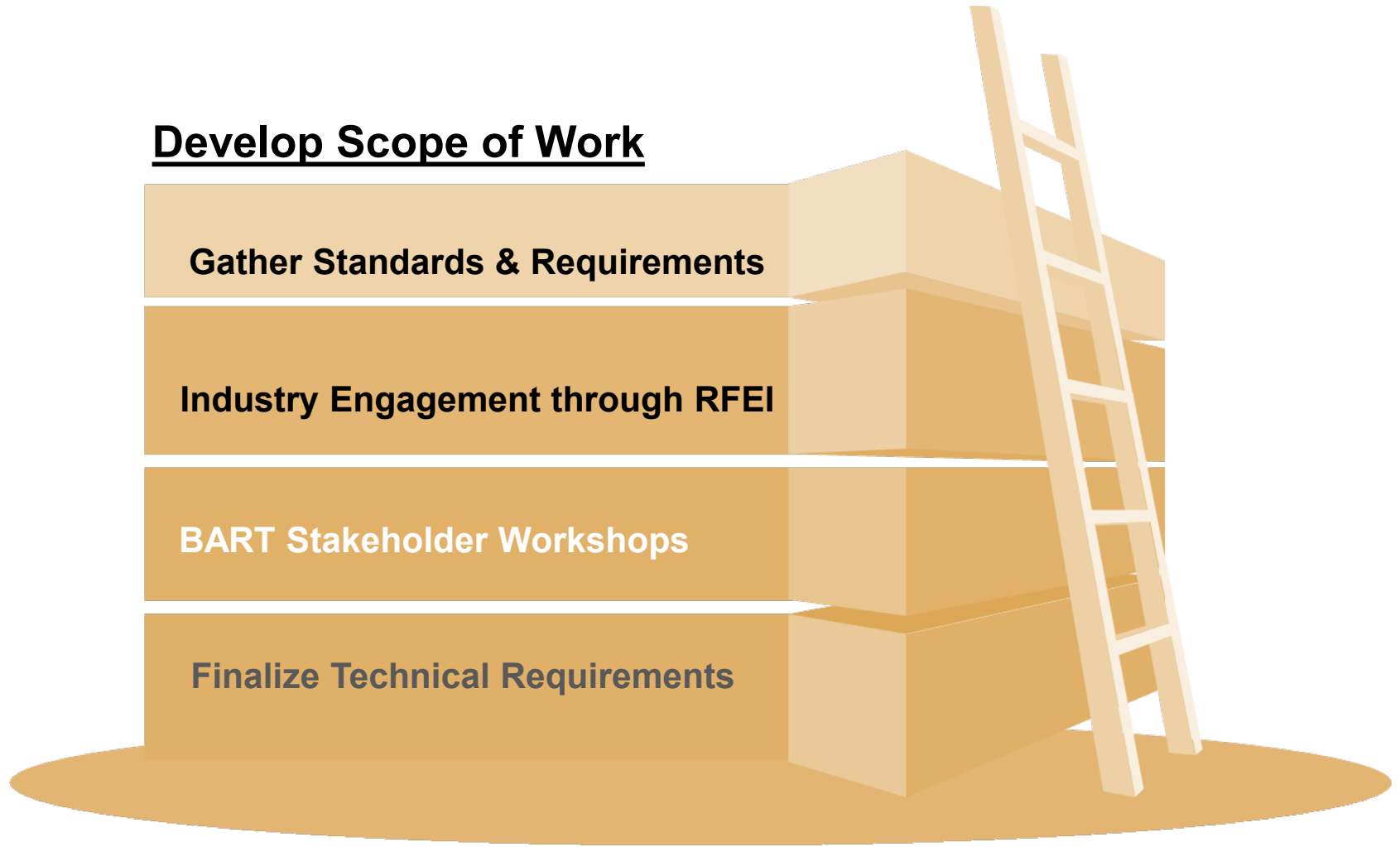

# RFP Building Blocks

## Determine Procurement Strategy

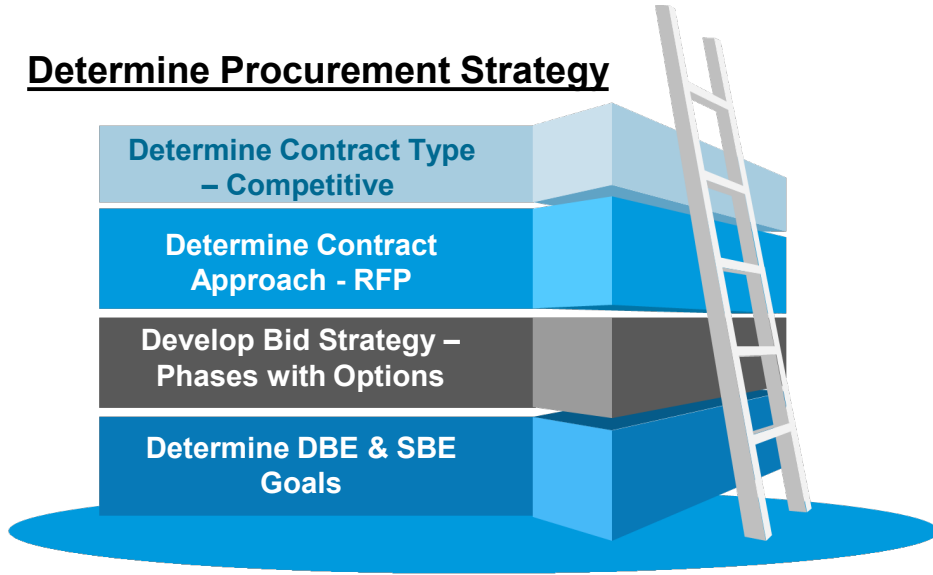

## Identify Risk & Liability Coverage

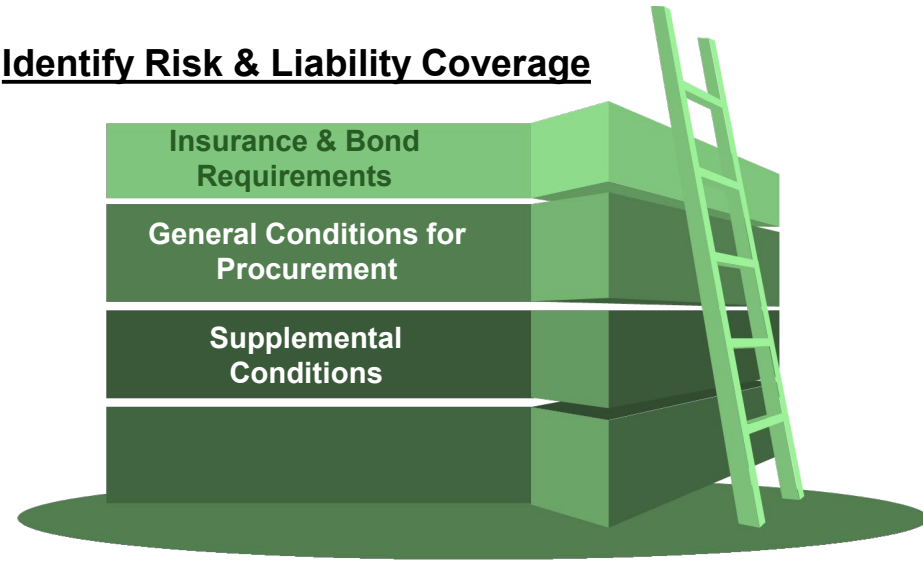

# BART's Commitment to DBEs

- Reviewed scope of work to identify opportunities for working with DBEs
- Identify appropriate North American Industry Classification System (NAICS) codes for contracting plan
- Outreach

Evaluate > 200 NAICS Codes



# The RFP

## 1 Volume

- Invitation to proposer
- Evaluation criteria
- Supplementary conditions

## 2 Volume

- Scope of Work
- Technical Specifications

## 3 Volume

- Exhibits
- Reference documents
- Drawings

# Hybrid Approach

## Vendor Supplied Off the Shelf Gate Path (from June 2021)



## BART Designed Gate Path

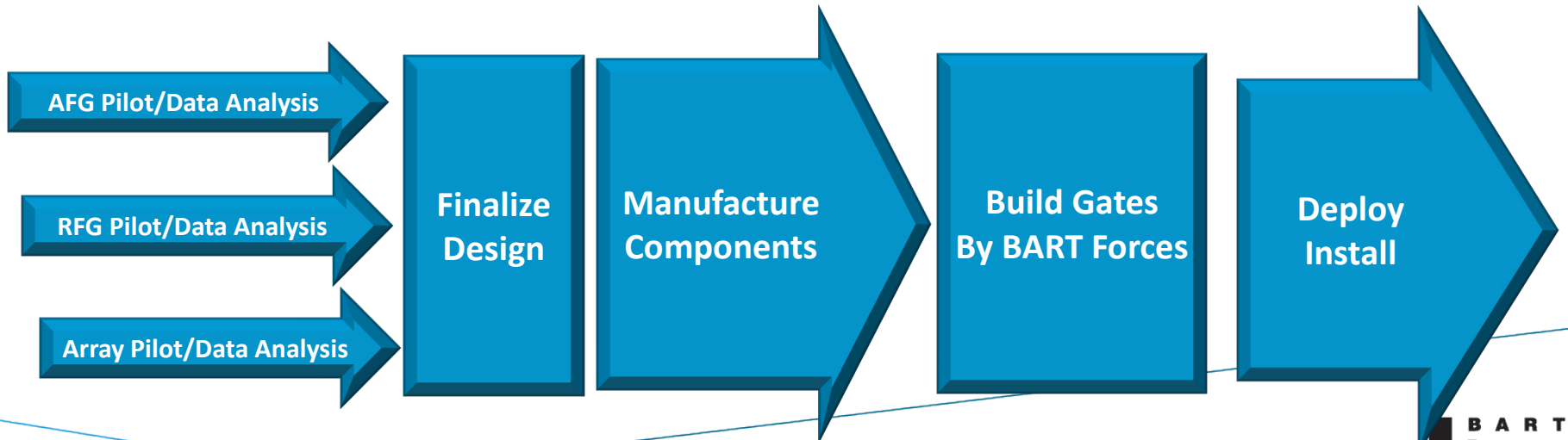



# FARE GATE EVOLUTION

*Cinch Mod*

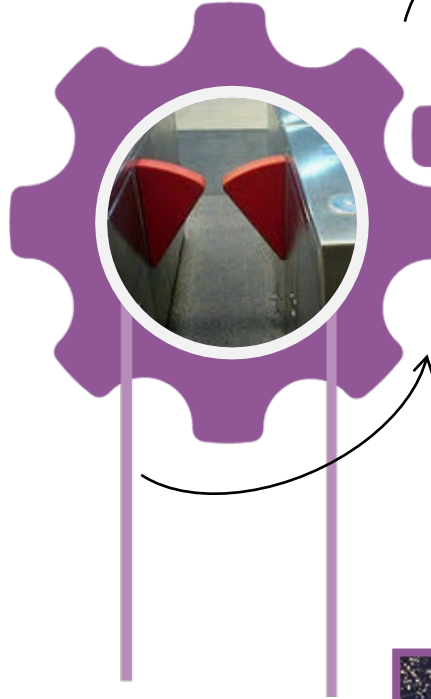

*Pneumatic AFG*



*Double Stack Barriers*



*Popup Barrier*



*Dual Swing Barrier AFG*

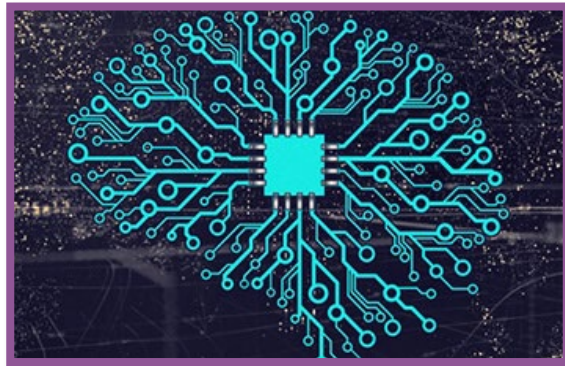

*Advanced Software Controls*



*Single Swing Barrier AFG*



# Leaf Evolution





# Lock Evolution

## Original Bolt Lock



New Lock



## Innovative Leaf Lock



# Double Barrier to Single Barrier Evolution

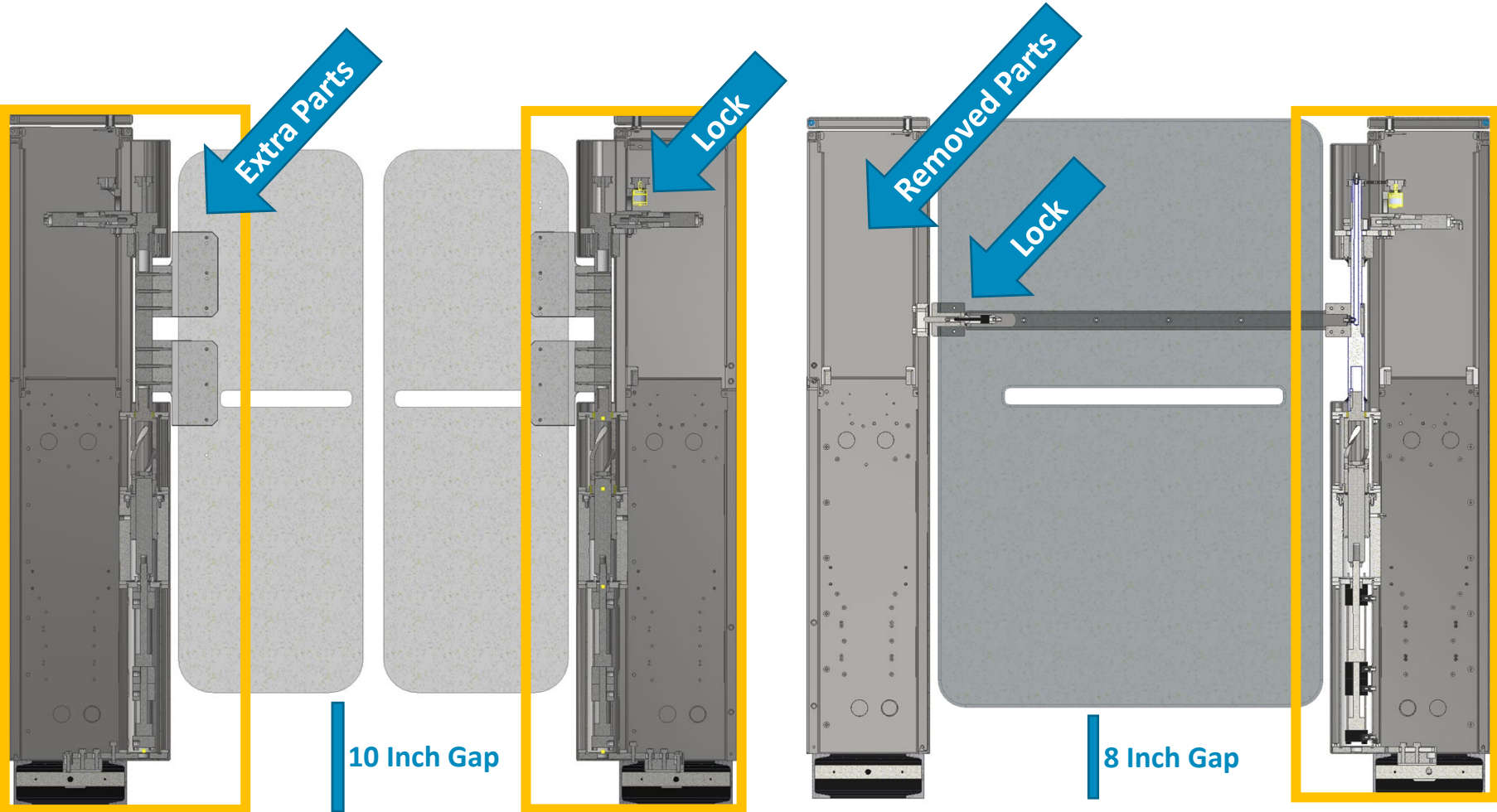

# Software Evolution

## Faregate Controller

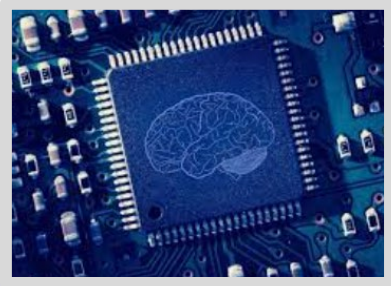

## Fare Gate Software Optimized:

- Soft Landing
- Barrier Positioning
- Increased Barrier Speed

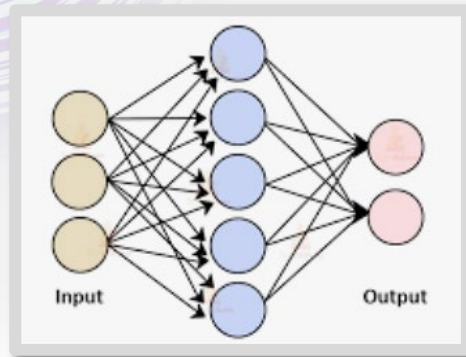

## Neural Network

# Console Mate Evolution



Modified Vendor Dummy Console

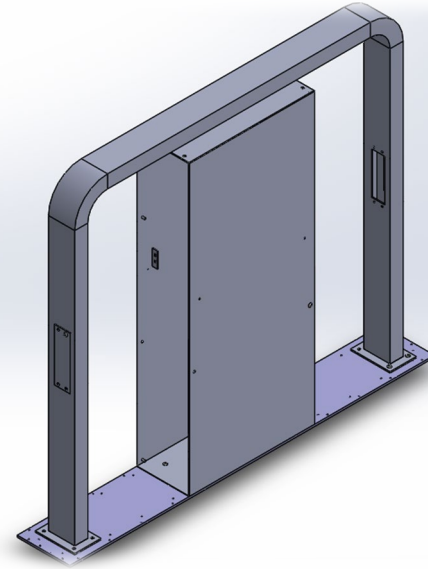

Internal Console Mate

**Combatted Supply Chain Issue and Saved Money!!!**



# Paper Ticket to Clipper



**No Ticket = Thinner Console**

# New Embarcadero Fare Gate

● Speeds Up Transfer to Muni

● Improves Accessibility

● Reduces Fare Evasion



Chris Panglinan  
@cap\_transport

A fare gate at the Embarcadero platform has been #1 on my wish list since I first lived here in 2006, and it's here! Transfer time between Muni and BART for elevator users has been cut from 5 min to 1 min. That's the equivalent of living 1-2 stops closer to work. Bravo 🍌 @SFBART



12:31 PM · Feb 8, 2022 · Twitter Web App

3 Retweets 2 Quote Tweets 47 Likes





# Platform Elevator Enclosure Accessible Gates

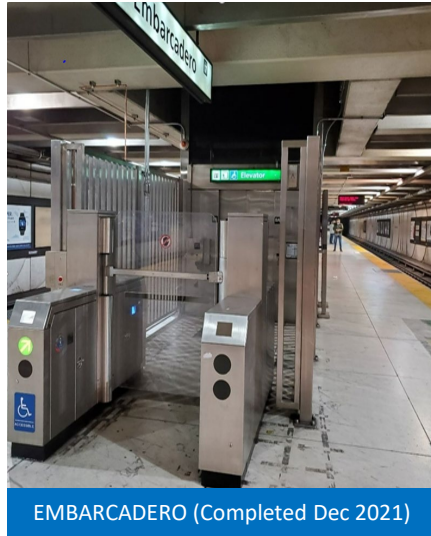

# Concourse Accessible Gates



CONCORD (Completed Oct 2020)

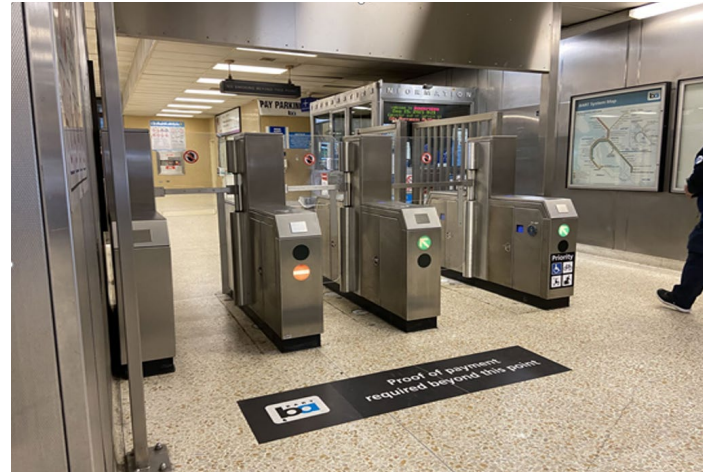

ROCKRIDGE ARRAY 1 (Completed Aug 2021)



COLISEUM (Completed Aug 2020)

# Fare Gates Completed and Planned



## Completed Enclosure and Elevator AFG Installation

- Coliseum
- Concord
- Montgomery
- **Bay Fair**
- **Balboa Park**
- **Embarcadero**



## Completed Array Retrofit

- **Rockridge - Array #1**

## Full Hardened Testing

- Rockridge



## Planned Enclosure and Elevator AFG Installation

- El Cerrito
- Rockridge
- Walnut Creek
- North Berkeley
- Civic Center
- Orinda
- Powell

# Funding

# Funding Forecast

## PROJECT TIMELINE



## FUNDING TIMELINE



total amount of funding in \$

% and \$ breakdown by funding source

% of \$90m, by year

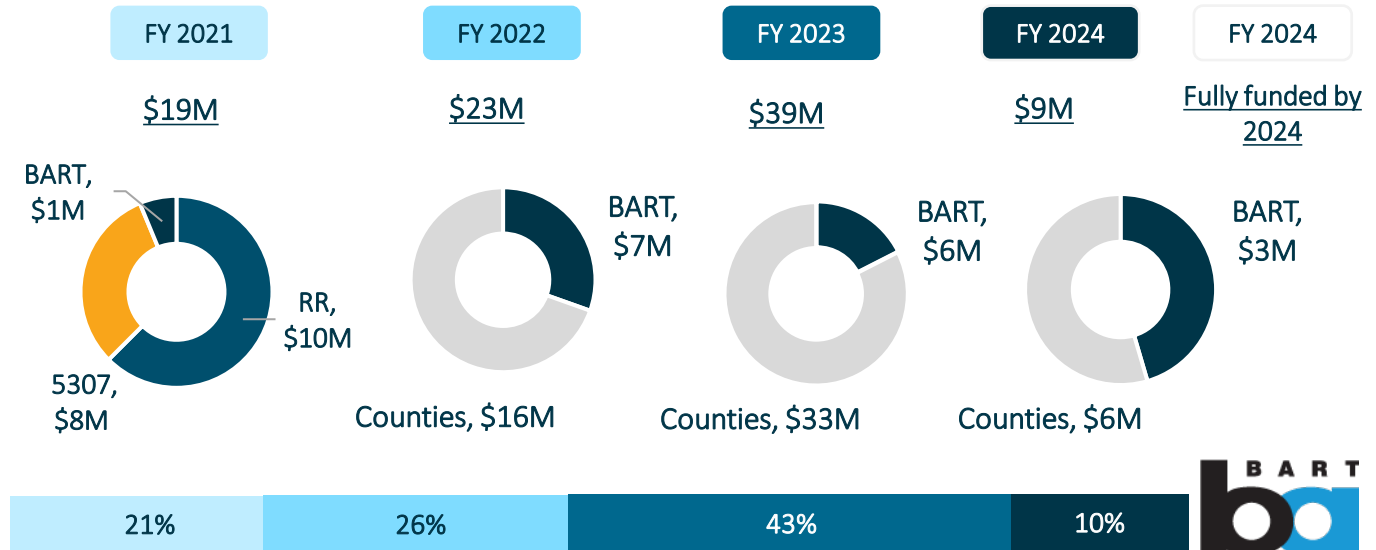



# Target Funding Plan

Next Generation Fare Gates Systemwide = \$90M

County/Segment	Total # of Fare Gates	% of Total	Total Cost (\$M)	Estimated County Contribution (\$M)	Estimated BART Contribution (\$M)
Alameda	277	39%	34.9	19.6	15.3
Contra Costa	117	16%	14.7	7.4	7.4
San Francisco (incl. SFO)	199	28%	25.0	12.5	12.5
San Mateo	82	11%	10.3	10.3	-
Santa Clara	40	6%	5.0	5.0	-
<b>Total</b>	<b>715</b>		<b>\$ 90.0</b>	<b>\$ 54.8</b>	<b>\$ 35.2</b>

# Secured Funding – \$47.2 million

## BART

Source	Amount (\$M)	Notes
FTA Section 5307/5337	18.0	MTC - administered TCP Program
FY22 Federal Appropriations Earmark	2.0	Member Request Senator Feinstein
Affordable Housing & Sustainable Communities	4.5	Awarded February 2022
Measure RR	10.0	Access Program Funds
Capital Allocations/Other Grants	7.2	Future Year Funds
<b>Total</b>	<b>41.7</b>	

## County

Source	Amount (\$M)	Notes
Subregional Transportation Mitigation Program	0.5	WCCTAC-Administered Program
Santa Clara VTA	5.0	SVRT O&M Agreement
<b>Total</b>	<b>5.5</b>	

- Funding ahead of schedule – had forecast to secure \$42M by end of FY22
- Since prior update, secured:
  - \$2M earmark in FY22 Federal Appropriations bill
  - \$4.5M across four AHSC grants

# Pending Funding – \$13.4M

## Pending - Notice of Award/Approval Pending

Source	Amount (\$M)	Notes
State Transportation Improvement Program	2.0	Pending CTC approval March 16-17
FY23 State Budget Request	7.9	4 Member Budget Requests submitted March
CCTA Measure J	3.5	Pending CCTA approval
<b>Total</b>	<b>13.4</b>	

- Submitted NGFG for additional funding opportunities, including:
  - \$2M STIP funds for Contra Costa County
  - \$7.9M across four FY23 State Budget requests to State Legislative Members
  - \$3.5M CCTA Measure J funds
- Will continue to pursue funding opportunities as they arise



# Planned & Identified Sources – \$43.8M

## BART District Counties

Source	Amount (\$M)	Notes
<b>Alameda County</b>		
Measure BB	19.6	Subject to ACTC Approval
<b>Total - Alameda County</b>	<b>19.6</b>	
<b>Contra Costa County</b>		
OBAG3/Future Sales Tax Measure	1.4	Subject to CCTA approval
<b>Total - Contra Costa County</b>	<b>1.4</b>	
<b>San Francisco County</b>		
New Transportation Sales Tax Measure	12.5	SFCTA Bd approved Exp Plan 3/8; 11/22 ballot
<b>Total - San Francisco County</b>	<b>12.5</b>	
<b>Total - Three BART District Counties</b>	<b>33.5</b>	
San Mateo County - Measure W	10.3	Call for projects deferred to time TBD
<b>Total - San Mateo County</b>	<b>10.3</b>	
<b>Total Counties</b>	<b>43.8</b>	

- Discussions continuing to advance with three BART county CTAs regarding balance of funding for county share

# Project 2 Year Look Ahead

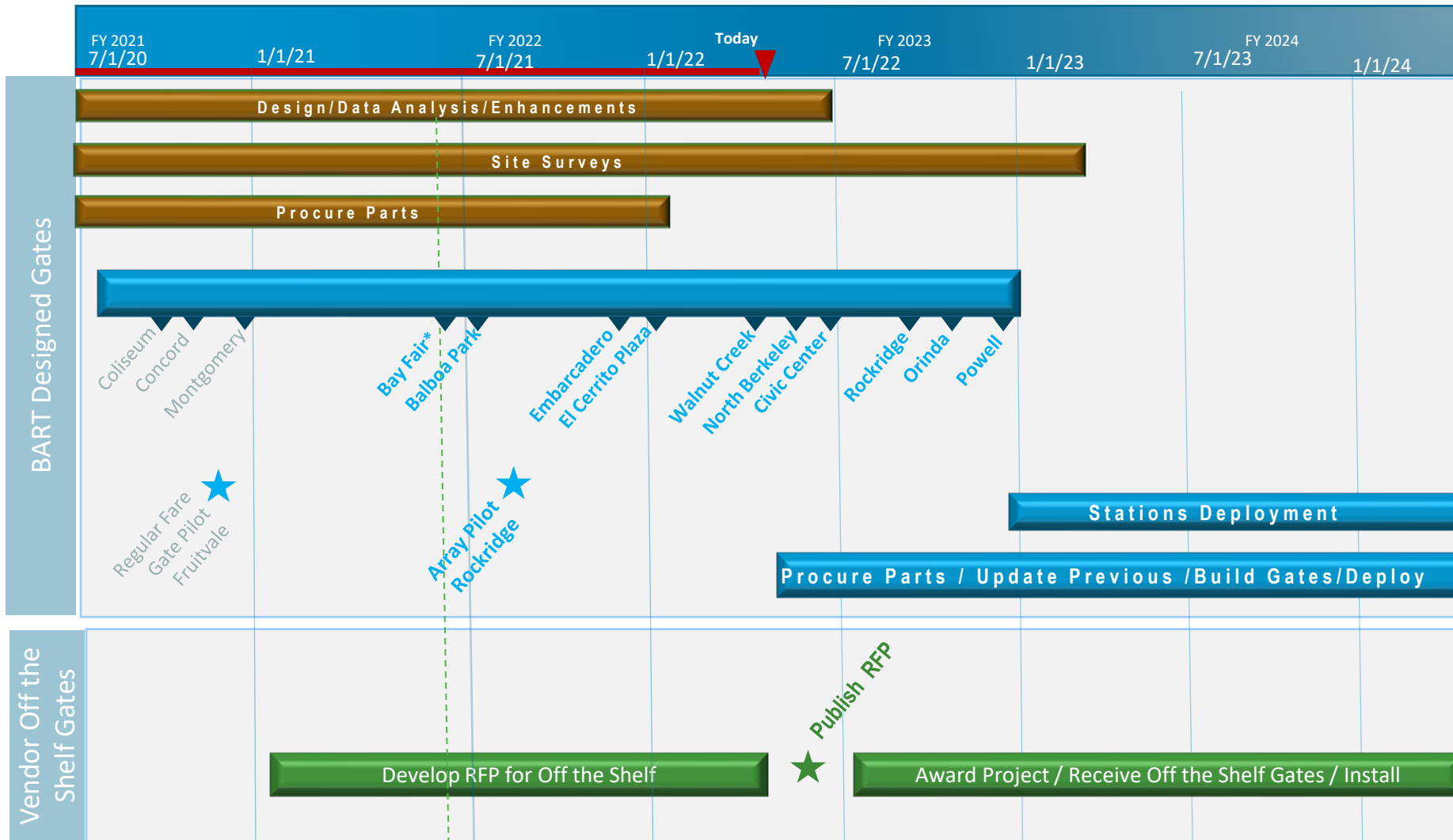

# Thank You!



Thank you

